

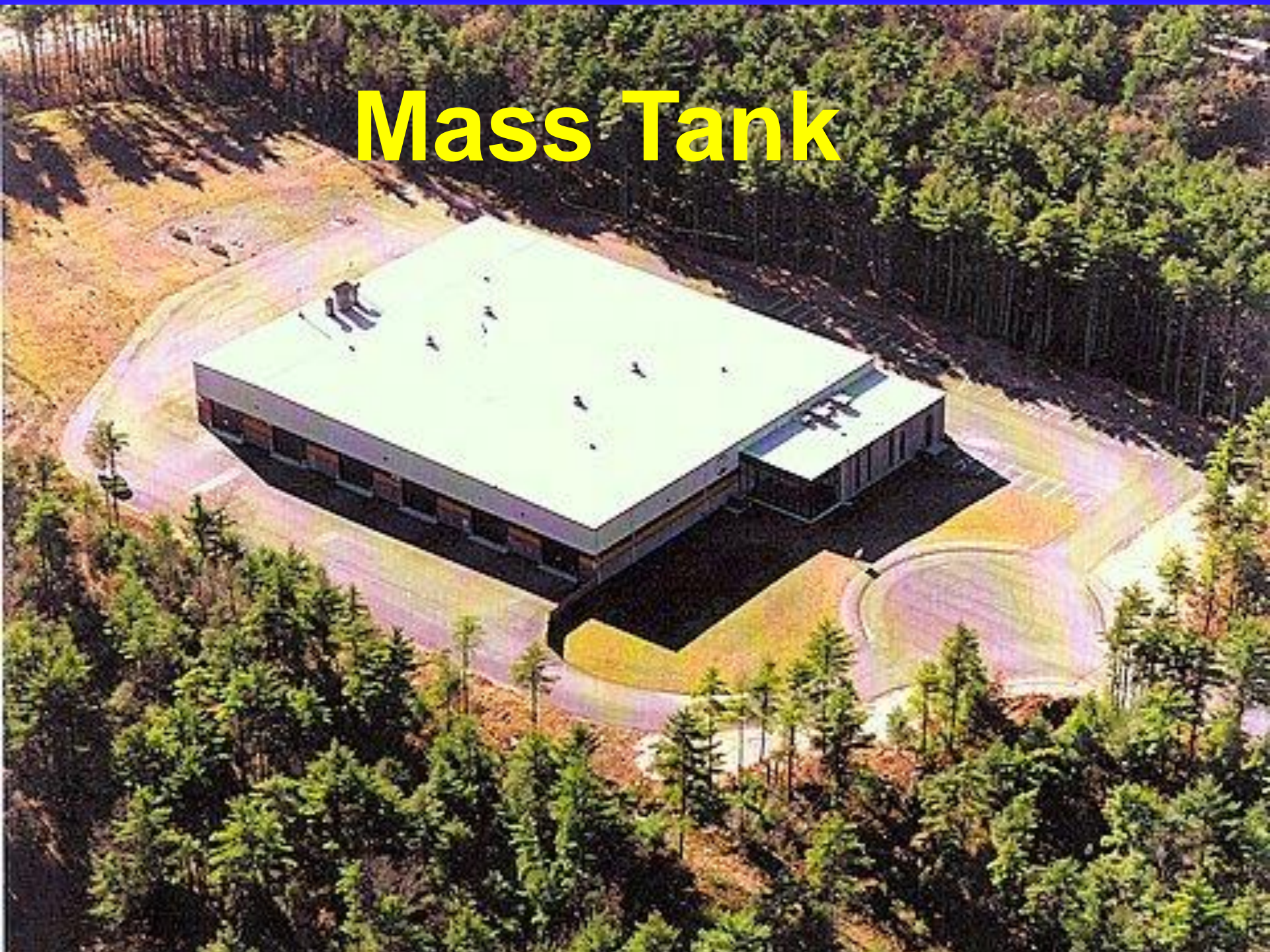

**MASS**

**TANK**

# Mass Tank



# Mass Tank Builds and Inspects Steel Tanks

- Above and Below Ground
- Shop and Field erected
- Atmospheric and Pressure
- Horizontal and Vertical
- Cylindrical and Rectangular
- Internal and external coatings
- Carbon and Stainless Steel
- Up to Thirty year warranty

# Mass Tank Inspection Services, LLC

***API 653, API 510, API 570, SP001-06, AWWA, Risk Based Assessments (for internal inspection interval extension).***

***Mechanical Integrity Assessments for compliance with Process Safety Management (OSHA PSM) and Risk Management Plan (EPA RMP).***

***Spill Prevention, Control & Countermeasures Plan tank inspection compliance.***

***Third Party Underground Storage Tank Inspections.***

***Valid Use Permit Inspections for tanks over 10,000 gallons.***

# AST-UST Tanks

- Constructed/Inspected To The Following Standards:

**UL**

**API**

**ASME**

**NFPA**

**NYC**

**AWWA**

**ABS**



MASS  
TANK  
masstank.com  
508-972-2888











**WIDE LOAD**

























MASS TANK, Inc.  
MIDDLEBORO MA  
508-847-8688

MASS TANK



PROFESSIONAL WATER  
TANK SERVICE















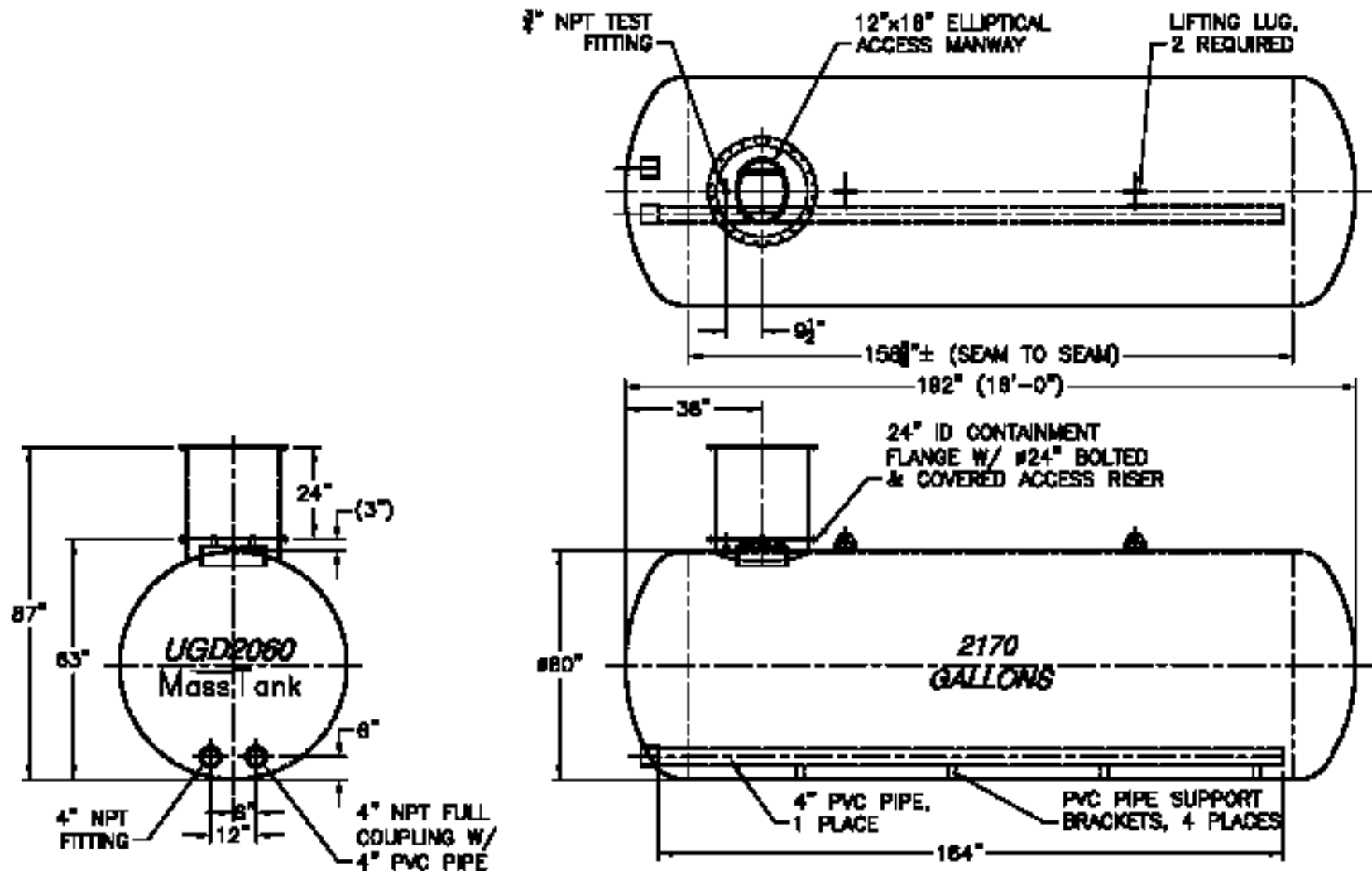

## 2,170 GALLON HYDRO TANK

## NOTES:

- 100 PSI HYDRO-PNEUMATIC WATER TANK IS DESIGNED AND BUILT IN GENERAL ACCORDANCE TO ASME CODE BUT NOT STAMPED
- RATED CAPACITY OF TANK: 2,170 GALLONS
- ESTIMATED WEIGHT OF TANK EMPTY: 3,700 LBS  
ESTIMATED WEIGHT, FULL OF WATER: 21,800 LBS
- TANK LINING: SSPC-SP10 BLAST PREP AND 2 COATS THINBED POLY-ESTER PLUS SERRA H140 NSF S1 LINER TO 8 MILS DFT. COLOR: WHITE
- TANK EXTERIOR: SSPC-SP6 BLAST PREP AND 2 COATS COOPERS CREEK ASPHALTUM COATING TO 4 MILS DFT. COLOR: BLACK
- MAXIMUM BURIAL COVERAGE: 6 FEET

 <b>MASS TANK SALES CORPORATION</b> PHONE: (508) 847-8859 FAX: (508) 847-3342			
OWNER:	<b>HIBBO ASSOCIATES</b>	DESCRIPTION:	<b>UGD2060</b>
NOTE:	SEE NOTES	DRAWN BY:	ESJ
SCALE:	1:40 (1"=40')	CHECKED BY:	ESJ
DATE:		DATE:	12OCT10
DESIGN TYPE:	SUBMITTAL	REV:	A
		DATE REV:	-
		SHEET NO.:	1 OF 1
		TOTAL SHEETS:	-

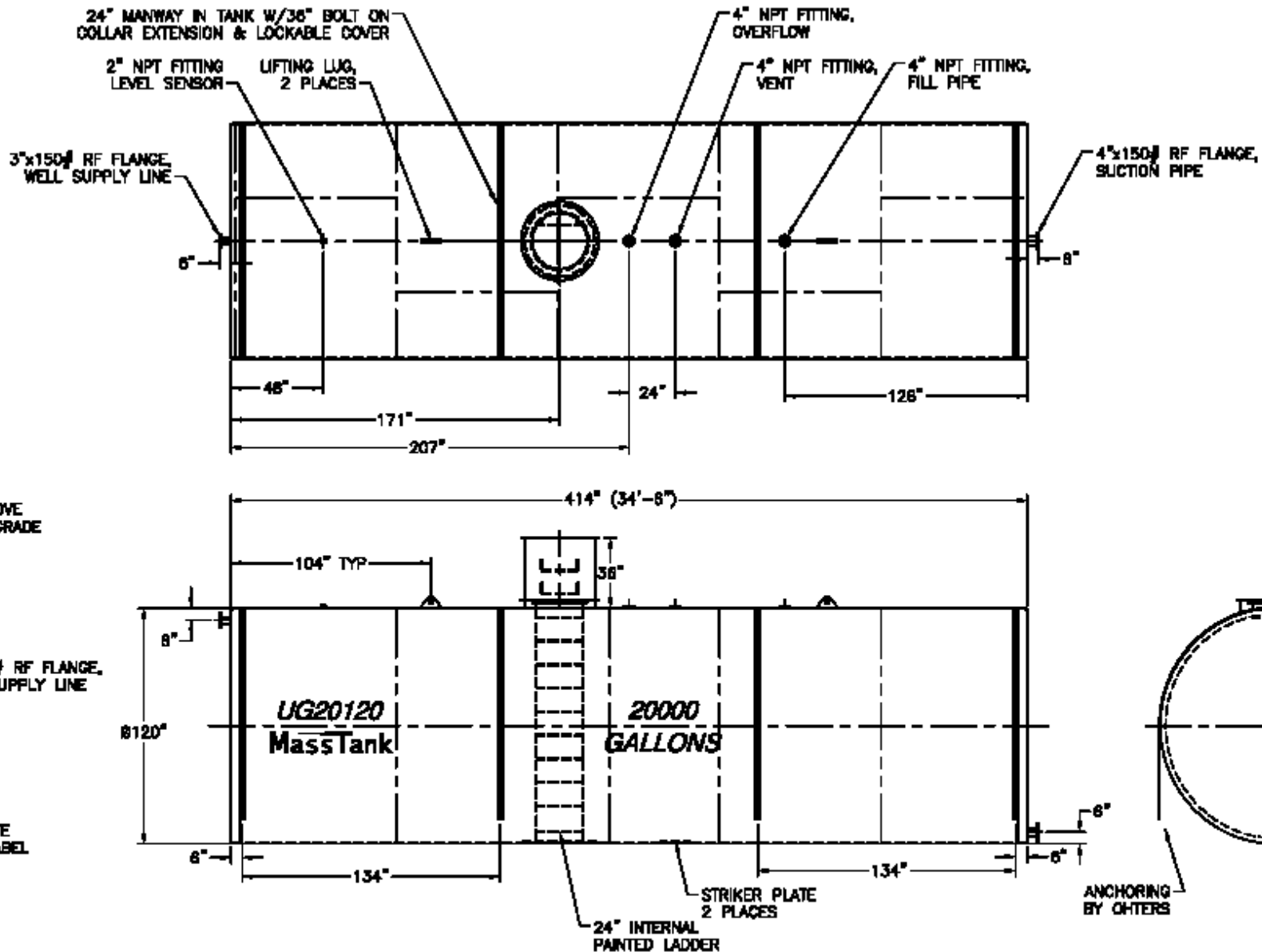

CONSTRUCTED IN GENERAL ACCORDANCE  
 SHOWN BUT NOT LABELED  
 DESIGNED FOR ATMOSPHERIC SERVICE ONLY  
 CAPACITY OF TANK SHALL BE: 20,000 GALLONS  
 AND 1/4" THICK FLAT FLANGED HEADS  
 WEIGHT OF TANK EMPTY: 14,300 LBS  
 FULL OF WATER: 181,000 LBS

6. TANK LINING: SSPC-SP10 BLAST PREP AND 2 COATS  
 SHERWIN WILLIAMS MACROPOXY 848 NSF EPOXY TO  
 8-12 MILS DFT, COLOR- WHITE
7. TANK EXTERIOR: SSPC-SP10 BLAST PREP AND 2 COATS  
 COOPER'S CREEK ASPHALTUM COATING TO 4 MILS DFT,  
 COLOR: BLACK
8. MAXIMUM BURIAL DEPTH: 6 FEET

**20,000 GALLON POTABLE WATER STORAGE TANK**  
**CENTURY MILL ESTATES**

<b>MASS TANK</b>		<b>MASS TANK SALES</b>	
PHONE: (508) 947-8820		PHONE: (508) 947-8820	
DESIGNED BY	RH WHITE	DATE	1-25-17
FOR	SEE NOTES	BY	RH WHITE
SCALE	1" = 1'-0"	APP'D	